

Universalmotor JP-160 NSP DZR
400 W, 50-60 Hz, IP 24

11.01.2021

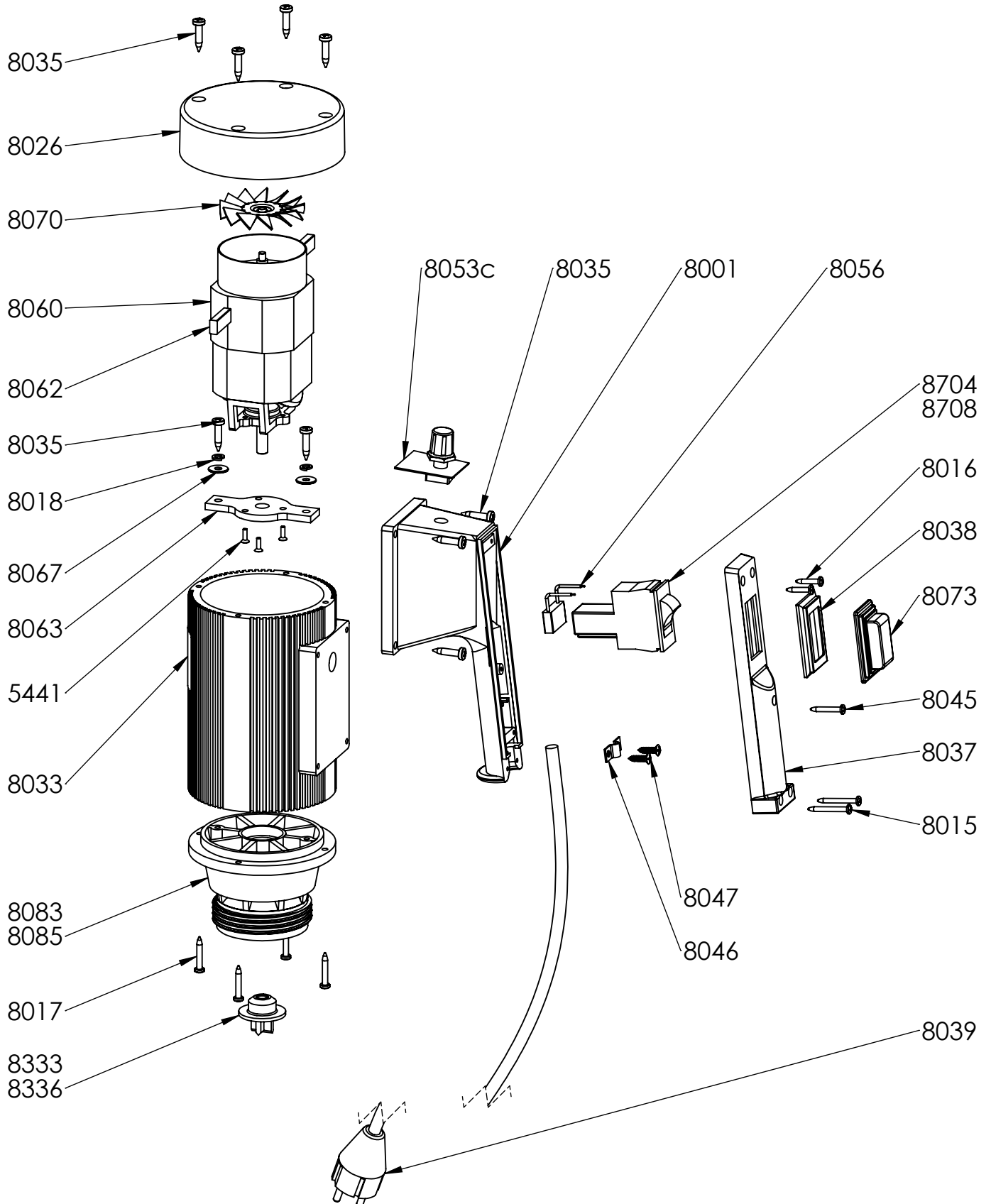

Universalmotor JP-160 NSP DZR
400 W, 50-60 Hz, IP 24

11.01.2021

PartNo	Beschreibung	Description	MENGE
8001	Handgriff Unterteil	Handle	1
8015	Linsen-Blechschaube	Screw	2
8016	Linsen-Blechschaube	Screw	2
8017	Linsenkopfschaube	Screw	4
8018	Sicherungsring	Locking ring	2
8026	Motordeckel	Motor cover	1
8033	Motorgehäuse	Motor housing	1
8035	Linsen-Blechschaube	Screw	10
8037	Handgriffdeckel	Handle cover	1
8038	Schalterrahmen	Switch frame	1
8039	5m Kabel 2-pol. mit Schukostecker	Cable with plug 5 meter	1
8045	Linsen-Blechschaube	Screw	1
8046	Zugentlastungsschelle	Clamp	1
8047	Linsensenk-Blechschaube	Screw	2
8056	Entstörfilter 220-240 V	Interference filter	1
8060	Motor JP-160, 230V 50Hz	Motor 230V, 50 Hz	1
8062	Kohlebürsten	Carbon brush	2
8063	Montageflansch	Connection flange	1
5441	Senkschraube	Screw	3
8070	Lüfter	Fan	1
8073	Durchsichtige Schalterabdeckung	Switch cover transparent	1
8083	Unteres Lagerschild	Lower housing	1
8085	Unteres Lagerschild, Klauenkupplung	Lower housing, coupling rotex	1
8333	Motorkupplung	Coupling	1
8336	Motorkupplung ROTEX GS14	Coupling ROTEX GS14	1
8067	Unterlegscheibe M5	Washer	2
8704	Schalter 230V, 50 Hz, 3,5A ohne USP	Switch 230V, 50 Hz, 3,5A w/o LVR	1
8708	Schalter 230V, 50 Hz, 3,5A mit USP	Switch 230V, 50 Hz, 3,5A w. LVR	1
8053c	Drehzahlregelung	Speed control	1